

GATE 2011

ME: Mechanical Engineering

Q.1 - Q.25 Carry one mark each.

1. The crystal structure of austenite is
(A) body centered cubic (C) hexagonal closed packed
(B) face centered cubic (D) body centered tetragonal

[Ans. B]

Austenite has FCC Crystal structure.

2. Which one among the following welding processes used non – consumable electrode?
(A) Gas metal arc welding (C) Gas tungsten arc welding
(B) Submerged arc welding (D) Flux coated arc welding

[Ans. C]

Gas tungsten arc welding user a non – consumable electrode made of tungsten.

3. A thin cylinder of inner radius 500 mm and thickness 10 mm is subjected to an internal pressure of 5 MPa. The average circumferential (hoop) stress in MPa is
(A) 100 (C) 500
(B) 250 (D) 1000

[Ans. B]

$$\text{Hoop stress, } = \frac{Pr}{t} = \frac{5 \times 500}{10} = 250 \text{ MPa}$$

4. The coefficient of restitution of a perfectly plastic impact is
(A) 0 (C) 2
(B) 1 (D) ∞

[Ans. A]

For, perfectly plastic collision, co – efficient of restitution = 0

5. If $f(x)$ is an even function and a is a positive real number, then $\int_{-a}^a f(x) dx$ equals
(A) 0 (B) a

(C) $2a$ (D) $2 \int_0^a f(x)dx$ **[Ans. D]**

By property 8 integrals.

6. The word **kanban** is most appropriately associated with
- (A) economic order quantity (C) capacity planning
 (B) just-in-time production (D) product design

[Ans. B]

Kanban literally known as 'sign board' of 'bill board' is concept related to. Just in time (JIT) production.

7. Cars arrive at a service station according to Poisson's distribution with a mean rate of 5 per hour. The service time per car is exponential with a mean of 10 minutes. At steady state, the average waiting time in the queue is
- (A) 10 minutes (C) 25 minutes
 (B) 20 minutes (D) 50 minutes

[Ans. D] $\lambda = 5$ per hour $\mu = 10$ minutes per car = 6 per hourAverage waiting time = $\frac{(\lambda/\mu)}{(\mu-\lambda)}$ = $\frac{(5/6)}{6/5} = \frac{5}{6}$ hours

= 50 minutes

8. The product of two complex number $1 + i$ and $2 - 5i$ is
- (A) $7 - 3i$ (C) $-3 - 4i$
 (B) $3 - 4i$ (D) $7 + 3i$

[Ans. A] $(1 + i) \times (2 - 5i)$ = $2 - 5i + 2i - 5i^2 = 7 - 3i$

9. Match the following criteria of material failure, under biaxial stresses σ_1 and σ_2 and yield stress σ_y , with their corresponding graphic representations:

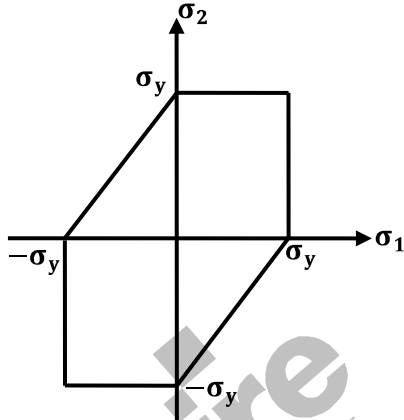
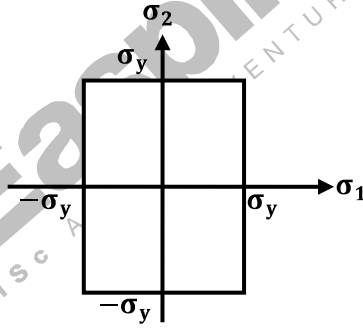
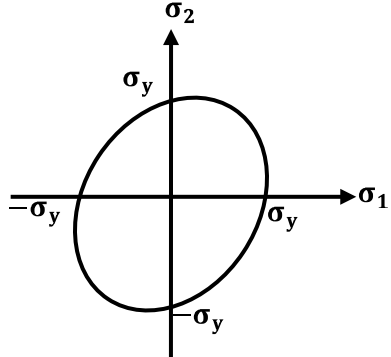
<p>P. Maximum – normal – stress criterion</p>	<p>L.</p> 
<p>Q. Maximum – distortion – energy criterion</p>	<p>M.</p> 
<p>R. Maximum – shear – stress criterion</p>	<p>N.</p> 

- (A) P – M, Q – L, R – N
- (B) P – N, Q – M, R – L

- (C) P – M, Q – N, R – L
- (D) P – N, Q – L, R – M

[Ans. C]

P – M, Q – N, R – L.

10. The contents of a well – insulated tank are heated by a resistor of 23Ω in which 10 A current is flowing. Consider the tank along with its contents as a thermodynamic system. The work done by the system and the heat transfer to the system are positive. The rates of heat (Q), work (W) and change in internal energy (ΔU) during the process in kW are
- (A) $Q = 0, W = -2.3, \Delta U = +2.3$ (C) $Q = -2.3, W = 0, \Delta U = -2.3$
 (B) $Q = +2.3, W = 0, \Delta U = +2.3$ (D) $Q = 0, W = +2.3, \Delta U = -2.3$

[Ans. B]

Heat added to the contents of the system.

$$Q = I^2 R = (10)^2 \times 23 = 2300 \text{ w}$$

$$Q = +2.3 \text{ Kw}$$

No. work is done by the system, $W = 0, U = +2.3 \text{ Kw}$

11. A pipe of 25 mm outer diameter carries steam. The heat transfer coefficient between the cylinder and surroundings is $5 \text{ W/m}^2\text{K}$. It is proposed to reduce the heat loss from the pipe by adding insulation having a thermal conductivity of 0.05 W/mK . Which one of the following statements is **TRUE**?
- (A) The outer radius of the pipe is equal to the critical radius.
 (B) The outer radius of the pipe is less than the critical radius.
 (C) Adding the insulation will reduce the heat loss.
 (D) Adding the insulation will increase the heat loss.

[Ans. C]

Adding insulation will reduce the heat loss.

12. What is $\lim_{\theta \rightarrow 0} \frac{\sin \theta}{\theta}$ equal to?

- (A) θ (C) 0
 (B) $\sin \theta$ (D) 1

[Ans. D]

Applying L' Hospitals rule, we have $\lim_{\theta \rightarrow 0} \frac{\cos \theta}{1} = \cos 0 = 1$

13. Eigen values of a real symmetric matrix are always
- (A) Positive (C) Real
 (B) Negative (D) Complex

[Ans. C]

Eigen values of a real symmetric matrix are always real.

14. Green sand mould indicates that

- (A) polymeric mould has been cured
 (B) mould has been totally dried
 (C) mould is green in colour
 (D) mould contains moisture

[Ans. D]

Green sand mould indicates that mould is not baked or dried. i.e., it contains moisture

15. A series expansion for the function $\sin \theta$ is

- (A) $1 - \frac{\theta^2}{2!} + \frac{\theta^4}{4!} - \dots$
 (B) $\theta - \frac{\theta^3}{3!} + \frac{\theta^5}{5!} - \dots$
 (C) $1 + \theta + \frac{\theta^2}{2!} + \frac{\theta^3}{3!} + \dots$
 (D) $\theta + \frac{\theta^3}{3!} + \frac{\theta^5}{5!} + \dots$

[Ans. B]

$$\sin x = x - \frac{x^3}{3!} + \frac{x^5}{5!} - \dots$$

16. A column has a rectangular cross – section of 10 mm × 20 mm and a length of 1 m. The slenderness ratio of the column is close to

- (A) 200
 (B) 346
 (C) 477
 (D) 1000

[Ans. B]

$$\text{Slenderness ratio, } = \frac{\text{Effective length}}{\text{Least radius of gyration}}$$

Least radius of gyration will be along the major axis.

20

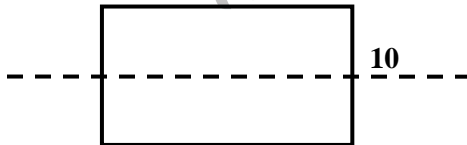

$$r = \sqrt{\frac{I}{A}} = \sqrt{\frac{20 \times (10)^3 / 12}{20 \times 10}}$$

$$r = \sqrt{\frac{100}{12}} = 2.887 \text{ mm.}$$

$$\text{Slenderness ratio, } = \frac{1000}{2.887} = 346$$

17. Heat and work are
- | | |
|--------------------------|---------------------|
| (A) Intensive properties | (C) Point functions |
| (B) Extensive properties | (D) Path functions |

[Ans. D]

Heat and work are path functions.

18. A hole is of dimension $\phi 9^{+0.015}_{+0}$ mm. The corresponding shaft is of dimension $\phi 9^{+0.010}_{+0.001}$ mm. The resulting assembly has
- | | |
|-----------------------|----------------------|
| (A) loose running fit | (C) transition fit |
| (B) close running fit | (D) interference fit |

[Ans. C]

Transition fit.

19. The operation in which oil is permeated into the pores of a powder metallurgy product is known as
- | | |
|---------------|------------------|
| (A) mixing | (C) impregnation |
| (B) sintering | (D) infiltration |

[Ans. C]

20. The maximum possible draft in cold rolling of sheet increases with the
- | | |
|---|-------------------------------|
| (A) increase in coefficient of friction | (C) decrease in roll radius |
| (B) decrease in coefficient of friction | (D) increase in roll velocity |

[Ans. A]

Maximum possible draft = $(h_0 - h_f)_{max} = \mu^2 R$

21. A double – parallelogram mechanism is shown in the figure. Note that PQ is a single link. The mobility of the mechanism is

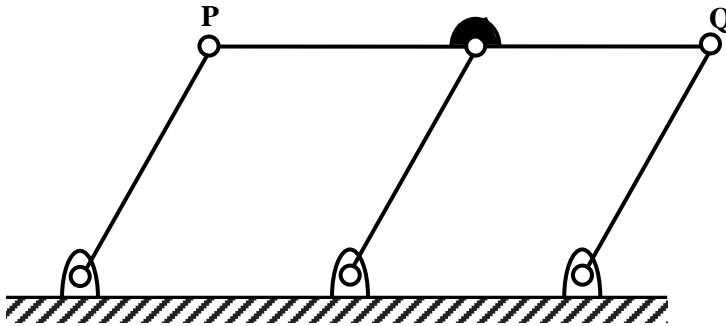

- (A) -1 (C) 1
 (B) 0 (D) 2

[Ans. C]

22. A simply supported beam PQ is loaded by a moment of 1 kN-m at the mid – span of the beam as shown in the figure. The reaction forces R_P and R_Q at supports P and Q respectively are

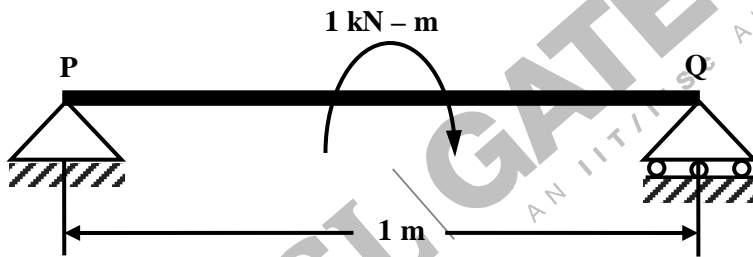

- (A) 1 kN downward, 1 kN upward (C) 0.5 kN downward, 0.5 kN upward
 (B) 0.5 kN upward, 0.5 kN downward (D) 1 kN upward, 1 kN upward

[Ans. A]

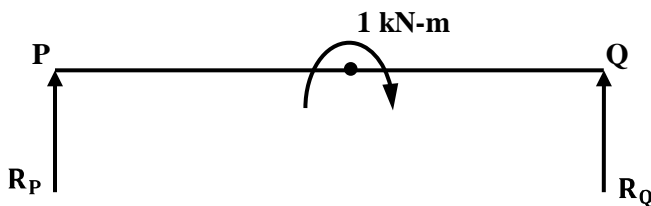

$$R_P = -R_Q$$

$$R_P \times 1 + 1 = 0$$

$$R_P = -1 \text{ kN}, R_Q = 1 \text{ kN}$$

23. In a condenser of a power plant, the steam condenses at a temperature of 60°C . The cooling water enters at 30°C and leaves at 45°C . The logarithmic mean temperature difference (LMTD) of the condenser is
- (A) 16.2°C (C) 30°C
 (B) 21.6°C (D) 37.5°C

[Ans. B]

$$LMTD = \frac{\theta_1 - \theta_2}{\ln\left(\frac{\theta_1}{\theta_2}\right)}$$

$$\theta_1 = 60^{\circ} - 30^{\circ} = 30^{\circ}\text{C}$$

$$\theta_2 = 60^{\circ} - 45^{\circ} = 15^{\circ}\text{C}$$

$$LMTD = \frac{30^{\circ} - 15^{\circ}}{\ln 2} = 21.6^{\circ}\text{C}$$

24. A streamline and an equipotential line in a flow field
- (A) are parallel to each other (C) intersect at an acute angle
 (B) are perpendicular to each other (D) are identical

[Ans. B]

Stream lines and equipotential lines are orthogonal

25. If a mass of moist air in an airtight vessel is heated to a higher temperature, then
- (A) specific humidity of the air increases (C) relative humidity of the air increases
 (B) specific humidity of the air decreases (D) relative humidity of the air decreases

[Ans. D]

R H Decreases

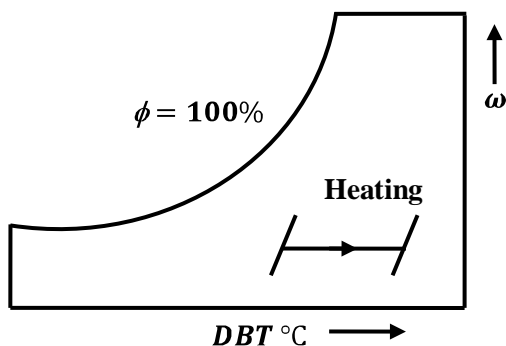

Q 26 to Q. 55 carry two marks each.

26. Match the following non – traditional machining processes with the corresponding material removal mechanism:

<i>Machining process</i>	<i>Mechanism of material removal</i>
P. Chemical machining	1. Erosion
Q. Electro – chemical machining	2. Corrosive reaction
R. Electro – discharge machining	3. Ion displacement
S. Ultrasonic machining	4. Fusion and vaporization

(A) P – 2, Q – 3, R – 4, S – 1

(C) P – 3, Q – 2, R – 4, S – 1

(B) P – 2, Q – 4, R – 3, S – 1

(D) P – 2, Q – 3, R – 1, S – 4

[Ans. A]

P – 2, Q – 3, R – 4, S – 1

27. A cubic casting of 50 mm side undergoes volumetric solidification shrinkage and volumetric solid contraction of 4% and 6% respectively. No riser is used. Assume uniform cooling in all directions. The side of the cube after solidification and contraction is

(A) 48.32 mm

(C) 49.94 mm

(B) 49.90 mm

(D) 49.96 mm

[Ans. A]

Volume of cube after solidification and contraction

$$V_2 = (1 - 0.04) (1 - 0.06) \times (50)^3$$

$$a_2^3 = 112800 \text{ mm}^3$$

$$a_2 = 48.32 \text{ mm}$$

28. A single – point cutting tool with 12° rake angle is used to machine a steel work – piece. The depth of cut, i.e. uncut thickness is 0.81 mm. The chip thickness under orthogonal machining condition is 1.8 mm. The shear angle is approximately

(A) 22°

(C) 56°

(B) 26°

(D) 76°

[Ans. B]

$$\alpha = 12^\circ$$

$$r_c = \frac{t_1}{t_2} = \frac{0.81}{1.8} = 0.44$$

$$\tan \varphi = \frac{r_c \cos \alpha}{1 - r_c \sin \alpha} = \frac{0.44 \times \cos 12}{1 - 0.44 \cos 12}$$

$$\tan \varphi = 6.476$$

$$\varphi = 26^\circ$$

29. Consider the following system of equations:

$$2x_1 + x_2 + x_3 = 0,$$

$$x_2 - x_3 = 0,$$

$$x_1 + x_2 = 0.$$

The system has

(A) a unique solution

(B) no solution

(C) infinite number of solutions

(D) five solutions

[Ans. C]

$$\begin{bmatrix} 2 & 1 & 1 \\ 0 & 1 & -1 \\ 1 & 1 & 0 \end{bmatrix}$$

$r < n$. Hence, infinite number of solutions.

30. A 1 kg block is resting on a surface with coefficient of friction $\mu = 0.1$. A force of 0.8 N is applied to the block as shown in the figure. The friction force is



(A) 0

(B) 0.8 N

(C) 0.98 N

(D) 1.2 N

[Ans. B]

$$N = 1 \times g = 9.81 \text{ N}$$

$$F = \mu N = 0.1 \times 9.81 = 0.98 \text{ N}$$

As theoretical frictional force is more than applied force P,

Hence, $F = P = 0.8 \text{ N}$.

31. A disc of mass m is attached to a spring of stiffness k as shown in the figure. The disc rolls without slipping on a horizontal surface. The natural frequency of vibration of the system is

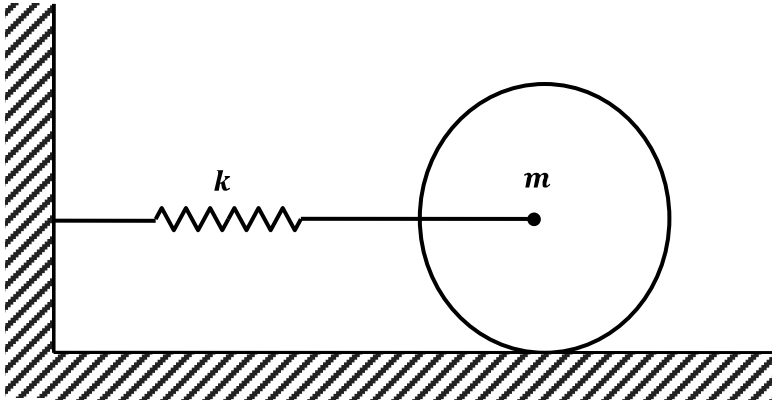

(A) $\frac{1}{2\pi} \sqrt{\frac{k}{m}}$
 (B) $\frac{1}{2\pi} \sqrt{\frac{2k}{m}}$

(C) $\frac{1}{2\pi} \sqrt{\frac{2k}{3m}}$
 (D) $\frac{1}{2\pi} \sqrt{\frac{3k}{2m}}$

[Ans. C]

Equation of motion $\frac{P\ddot{\theta}}{r} + m\ddot{x} + kx = 0$; $\frac{I}{r^2}\ddot{x} + m\ddot{x} + kx = 0$

$$\omega = \sqrt{\frac{k}{m + I/r^2}} \quad f = \frac{1}{2\pi} \sqrt{\frac{k}{m + \frac{m}{2}}} = \frac{1}{2\pi} \sqrt{\frac{2k}{3m}}$$

32. A ideal Brayton cycle, operating between the pressure limits of 1 bar and 6 bar, has minimum and maximum temperatures of 300 K and 1500 K. The ratio of specific heats of the working fluid is 1.4. The approximate final temperatures in Kelvin at the end of the compression and expansion processes are respectively

- (A) 500 and 900
 (B) 900 and 500
 (C) 500 and 500
 (D) 900 and 900

[Ans. A]

$$T_1 = 300 \text{ K}, T_3 = 1500 \text{ K}$$

$$P_1 = P_4 = 1 \text{ bar}, P_2 = P_3 = 6 \text{ bar}$$

$$r = 1.4$$

$$\frac{T_2}{T_1} = \left(\frac{P_2}{P_1}\right)^{\frac{r-1}{r}}$$

$$T_2 = 300 \times (6)^{\frac{1.4-1}{1.4}} = 500 \text{ K}$$

$$\frac{T_3}{T_4} = \left(\frac{P_3}{P_4}\right)^{\frac{r-1}{r}}$$

$$T_4 = \frac{1500}{(6)^{\frac{1.4-1}{1.4}}} = 900 \text{ K}$$

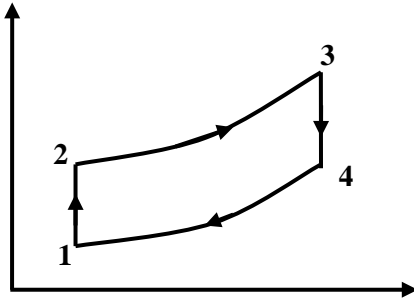

33. A spherical steel ball of 12 mm diameter is initially at 1000 K. It is slowly cooled in a surrounding of 300 K. The heat transfer coefficient between the steel ball and the surrounding is 5 W/m²K. The thermal conductivity of steel is 20 W/mK. The temperature difference between the centre and the surface of the steel ball is
- (A) large because conduction resistance is far higher than the convective resistance.
 (B) large because conduction resistance is far less than the convective resistance.
 (C) small because conduction resistance is far higher than the convective resistance.
 (D) small because conduction resistance is far less than the convective resistance.

[Ans. B]

34. A pump handing a liquid raises its pressure from 1 bar to 30 bar. Take the density of the liquid as 990 kg/m³. The isentropic specific work done by the pump in kJ/kg is
- (A) 0.10 (C) 2.50
 (B) 0.30 (D) 2.93

[Ans. D]

$$\begin{aligned} \text{Work done} &= v (P_2 - P_1) \\ &= \frac{1}{\rho} (P_2 - P_1) = \frac{(30 - 1) \times 100}{990} \text{ kJ/kg} \\ &= 2.93 \text{ kJ/kg} \end{aligned}$$

35. The crank radius of a single – cylinder I. C. engine is 60 mm and the diameter of the cylinder is 80 mm. The swept volume of the cylinder in cm³ is

- (A) 48 (C) 302
(B) 96 (D) 603

[Ans. D]

$$\begin{aligned} \text{Swept volume} &= \frac{\pi}{4} d^2 \cdot 2r \\ &= \frac{\pi}{4} \times (80)^2 \times 2 \times 60 \times 10^{-3} \text{ cm}^3 \\ &= 603 \text{ cm}^3 \end{aligned}$$

36. The ratios of the laminar hydrodynamic boundary layer thickness to thermal boundary layer thickness of flows of two fluids P and Q on a flat plate are $\frac{1}{2}$ and 2 respectively. The Reynolds number based on the plate length for both the flows is 10^4 . The Prandtl and Nusselt numbers for P are $\frac{1}{8}$ and 35 respectively. The Prandtl and Nusselt number for Q are respectively
- (A) 8 and 140 (C) 4 and 70
(B) 8 and 70 (D) 4 and 35

[Ans. A]

$$\begin{aligned} \left(\frac{\delta}{\delta t}\right)_P &= (P_{rP})^n \\ \frac{1}{2} &= \left(\frac{1}{8}\right)^n \Rightarrow n = 1/3 \\ \left(\frac{\delta}{\delta t}\right)_Q &= (P_{rQ})^n \Rightarrow P_{rQ} = (2)^3 = 8 \\ \text{For laminar flow} \\ N_{uQ} &\propto (P_r)^n \\ \frac{N_{uQ}}{N_{uP}} &= \left(\frac{P_{rQ}}{P_{rP}}\right)^{1/3} \\ N_{uQ} &= 35 \times \left(\frac{8}{1/8}\right)^{1/3} = 35 \times 4 = 140 \end{aligned}$$

37. The shear strength of a sheet metal is 300 MPa. The blanking force required to produce a blank of 100 mm diameter from a 1.5 mm thick sheet is close to
- (A) 45 kN (C) 141 kN
(B) 70 kN (D) 3500 kN

[Ans. C]

$$\begin{aligned} \text{Blanking Force, } F &= \sigma \cdot \pi D t \\ &= 300 \times \pi \times 100 \times 1.5 \times 10^{-3} \\ &= 141.3 \text{ kN} \end{aligned}$$

38. A mass of 1 kg is attached to two identical springs each with stiffness $k = 20 \text{ kN/m}$ as shown in the figure. Under frictionless condition, the natural frequency of the system in Hz is close to

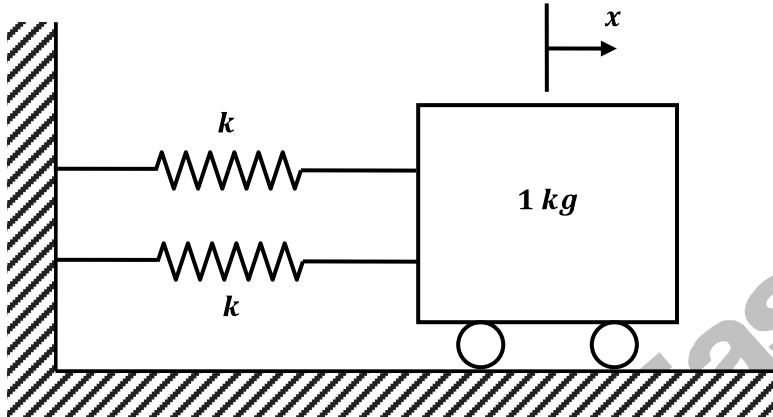

- (A) 32
(B) 23
(C) 16
(D) 11

[Ans. A]

$$\begin{aligned} f &= \frac{1}{2\pi} \sqrt{\frac{2k}{m}} \\ &= \frac{1}{2\pi} \sqrt{\frac{2 \times 20 \times 10^3}{1}} \\ &= \frac{200}{2\pi} = 31.8 \text{ Hz} \end{aligned}$$

39. An unbiased coin is tossed five times. The outcome of each toss is either a head or a tail. The probability of getting at least one head is

- (A) $\frac{1}{32}$
(B) $\frac{13}{32}$
(C) $\frac{16}{32}$
(D) $\frac{31}{32}$

[Ans. D]

$$\begin{aligned} \text{Required probability} &= 1 - 5c_0 \left(\frac{1}{2}\right)^1 \left(\frac{1}{2}\right)^4 \\ &= 1 - \frac{1}{32} = \frac{31}{32} \end{aligned}$$

40. Consider the differential equation $\frac{dy}{dx} = (1 + y^2)x$. The general solution with constant c is

(A) $y = \tan \frac{x^2}{2} + \tan c$

(C) $y = \tan^2 \left(\frac{x}{2}\right) + c$

(B) $y = \tan^2 \left(\frac{x}{2} + c\right)$

(D) $y = \tan \left(\frac{x^2}{2} + c\right)$

[Ans. D]

$$\frac{dy}{dx} = (1 + y^2)x$$

$$\frac{dy}{1 + y^2} = x dx$$

$$\tan^{-1} y = \frac{x^2}{2} + c$$

$$y = \tan \left(\frac{x^2}{2} + c\right)$$

41. A stone with mass of 0.1 kg is catapulted as shown in the figure. The total force F_x (in N) exerted by the rubber band as a function of distance x (in m) is given by $F_x = 300x^2$. If the stone is displaced by 0.1 m from the un-stretched position ($x = 0$) of the rubber band, the energy stored in the rubber band is

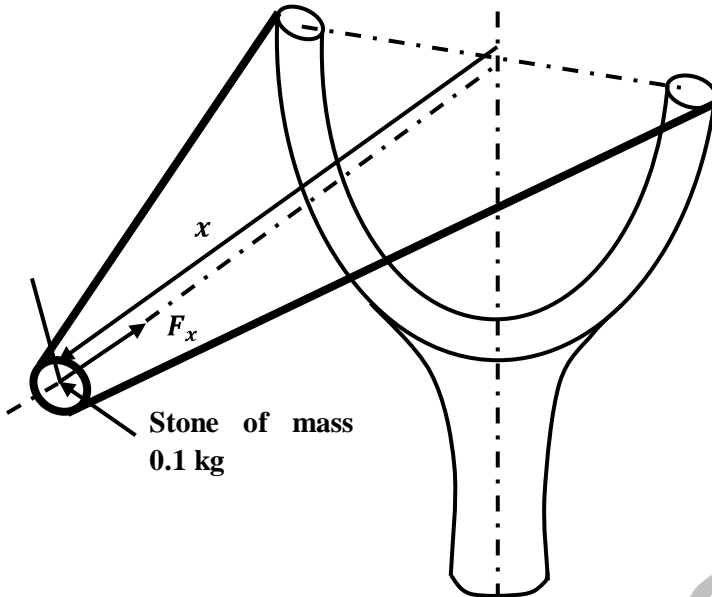

(A) 0.01 J

(B) 0.1 J

(C) 1 J

(D) 10 J

[Ans. B]

$$\text{Energy stored} = \text{work done} = \int_0^{0.1} F_x dx$$

$$= \int_0^{0.1} 300 x^2 dx = [100 x^3]_0^{0.1}$$

$$= 0.1 J$$

42. For the four – bar linkage shown in the figure, the angular velocity of link AB is 1 rad/s. The length of link CD is 1.5 times the length of link AB. In the configuration shown, the angular velocity of link CD in rad/s is

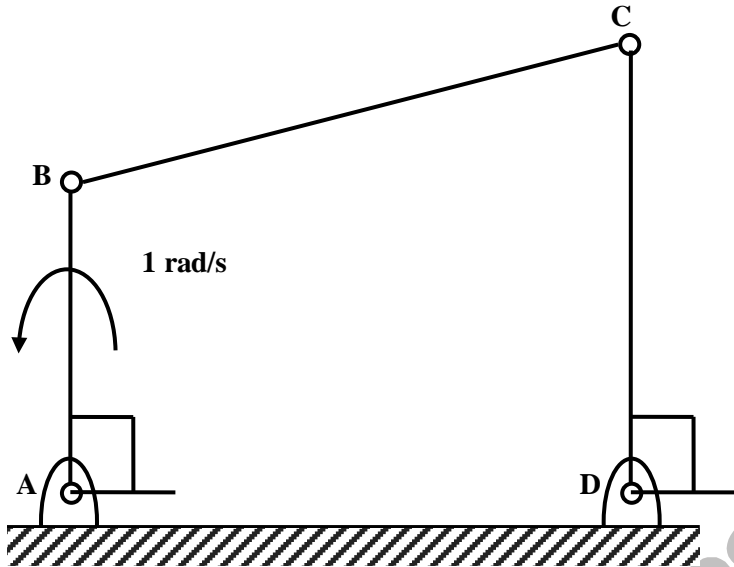

(A) 3

(B) $\frac{3}{2}$

(C) 1

(D) $\frac{2}{3}$ **[Ans. D]**

Velocity of link AB = Velocity of link CD

$$AB \times \omega_{AB} = CD \times \omega_{CD}$$

$$\omega_{CD} = \frac{1}{1.5} = \frac{2}{3}$$

43. Two identical ball bearings P and Q are operating at loads 30 kN and 45 kN respectively. The ratio of the life of bearing P to the life of bearing Q is

(A) 81/16

(C) 9/4

(B) 27/8

(D) 3/2

[Ans. B]

$$\text{Life} \propto \left(\frac{1}{P}\right)^3$$

$$\frac{L_Q}{L_P} = \left(\frac{P_P}{P_Q}\right)^3 = \left(\frac{30}{45}\right)^3 = \frac{8}{27}$$

$$\frac{L_P}{L_Q} = \frac{27}{8}$$

44. The integral $\int_1^3 \frac{1}{x} dx$, when evaluated by using Simpson's 1/3 rule on two equal subintervals each of length 1, equals
- (A) 1.000 (C) 1.111
(B) 1.098 (D) 1.120

[Ans. C]

$$\int_1^3 \frac{1}{x} dx = \frac{h}{3} (y_1 + y_3 + 4y_2)$$

$$= \frac{1}{3} \left(\frac{1}{1} + \frac{1}{3} + 4 \times \frac{1}{2} \right)$$

$$= 1.111$$

45. The values of enthalpy of steam at the inlet and outlet of a steam turbine in a Rankine cycle are 2800 kJ/kg and 1800 kJ/kg respectively. Neglecting pump work, the specific steam consumption in kg/kW-hour is
- (A) 3.60 (C) 0.06
(B) 0.36 (D) 0.01

[Ans. A]

$$\text{Specific steam consumption in kg/kw-hr} = \frac{3600}{h_1 - h_2}$$

$$= \frac{3600}{2800 - 1800} = 3.60$$

46. A torque T is applied at the free end of a stepped rod of circular cross – sections as shown in the figure. The shear modulus of the material of the rod is G . The expression of d to produce an angular twist θ at the free end is

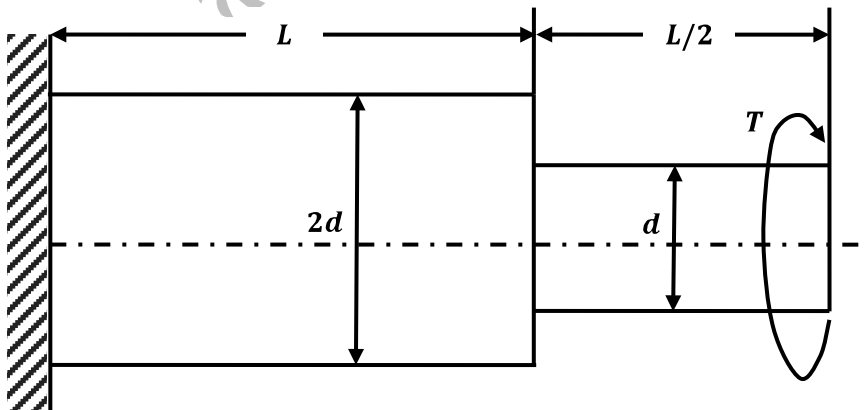

(A) $\left(\frac{32TL}{\pi\theta G}\right)^{\frac{1}{4}}$

(C) $\left(\frac{16TL}{\pi\theta g}\right)^{\frac{1}{4}}$

(B) $\left(\frac{18TL}{\pi\theta G}\right)^{\frac{1}{4}}$

(D) $\left(\frac{2TL}{\pi\theta G}\right)^{\frac{1}{4}}$

[Ans. B]

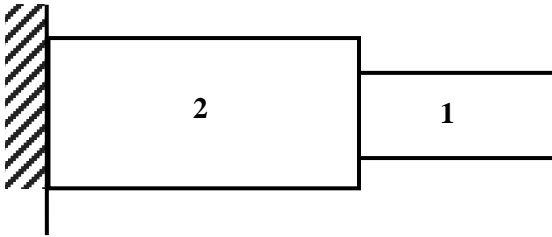

$$\theta = \theta_1 + \theta_2$$

$$\theta = \frac{32T(L\pi/2)}{\pi d^4 G} + \frac{32 T L}{\pi (2d)^4 G}$$

$$\theta = \frac{16 T L}{\pi d^4 G} + \frac{2 T L}{\pi d^4 G}$$

$$d^4 = \frac{18 T L}{\pi \theta G} \Rightarrow d = \left[\frac{18 T L}{\pi \theta G}\right]^{\frac{1}{4}}$$

47. Figure shows the schematic for the measurement of velocity of air (density = 1.2 kg/m^3) through a constant – area duct using a pitot tube and a water – tube manometer. The differential head of water (density = 1000 kg/m^3) in the two columns of the manometer is 10 mm. Take acceleration due to gravity as 9.8 m/s^2 . The velocity of air in m/s is

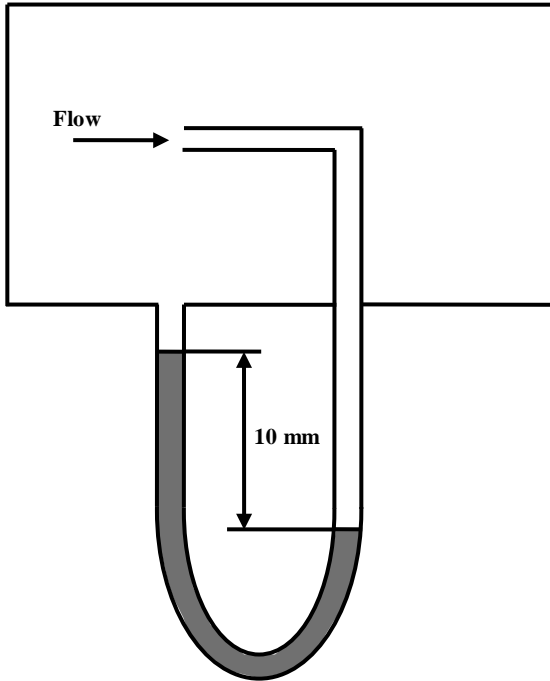

- (A) 6.4
(B) 9.0

- (C) 12.8
(D) 25.6

[Ans. C]

$$\frac{1}{2} \rho_{air} V_{air}^2 = \rho_w g h$$

$$V_{air}^2 = 2 \times \frac{1000 \times 9.8 \times 0.01}{1.2}$$

$$V_{air} = 12.8 \text{ m/s}$$

Common Data Questions

Common Data for Question Q. 48 and Q 49:

One unit of product P_1 requires 3 kg of resource R_1 and 1 kg of resource R_2 . One unit of product P_2 requires 2 kg of resource R_1 and 2 kg of resource R_2 . The profits per unit by selling product P_1 and P_2 are Rs. 2000 and Rs. 3000 respectively. The manufacturer has 90 kg of resource R_1 and 100 kg of resource R_2 .

48. The manufacturer can make a maximum profit of Rs.

- (A) 60000
(B) 135000
(C) 150000
(D) 200000

[Ans. B]

Maximize $2000 P_1 + 3000 P_2$

S. t.

$$3P_1 + 2P_2 \leq 90$$

$$P_1 + 2P_2 \leq 100, P_1, P_2 \geq 0$$

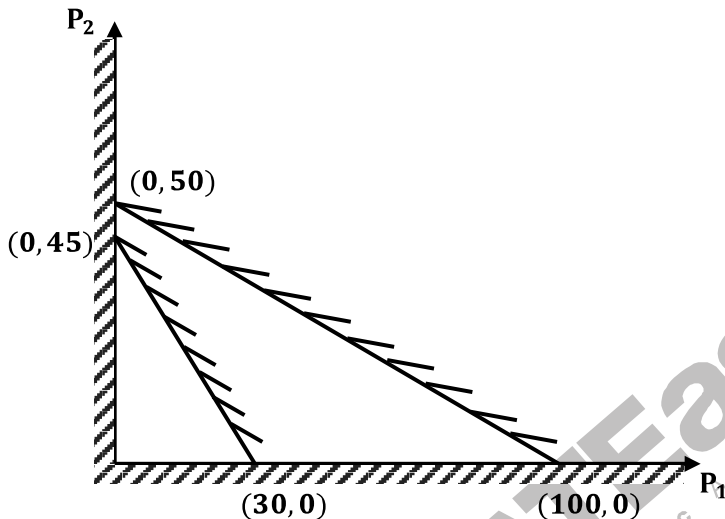

Maximum of (0, 45)

$$2000 \times 0 + 3000 \times 45 = 135000$$

and

$$2000 \times 30 + 3000 \times 0 = 60000$$

Maximum profit = 135,000

49. The unit worth resource R_2 , i.e. dual price of resource R_2 in Rs. per kg is

- (A) 0 (C) 1500
(B) 1350 (D) 2000

[Ans. C]

$$R_2 \text{ resource used} = 45 \times 2 = 90 \text{ kg}$$

$$\text{Unit worth} = \frac{\text{Profit}}{\text{Quantity}} = \frac{135000}{90} \\ = 1500$$

Common Data for Question Q. 50 and Q 51:

In an experimental set – up, air flows between two stations P and Q adiabatically. The direction of flow depends on the pressure and temperature conditions maintained at P and Q. The conditions at station P are 150 kPa and 350 K. The temperature at station Q is 300 K.

The following are the properties and relations pertaining to air:

Specific heat at constant pressure, $c_p = 1.005 \text{ kJ.kgK}$;

Specific heat at constant volume, $c_v = 0.718 \text{ kJ/kgK}$;

Characteristic gas constant, $R = 0.287 \text{ kJ.kgK}$.

Enthalpy, $h = c_p T$.

Internal energy, $u = c_v T$.

50. If the pressure at station Q is 50 kPa, the change in entropy ($s_Q - s_P$) in kJ/kgK is

- (A) -0.155 (C) 0.160
(B) 0 (D) 0.355

[Ans. B]

Adiabatic flow, $\Delta Q = 0$

51. If the air has to flow from station P to station Q, the maximum possible value of pressure in kPa at station Q is close to

- (A) 50 (C) 128
(B) 87 (D) 150

[Ans. B]

$$\frac{P_Q}{P_P} = \left(\frac{T_Q}{T_P}\right)^{\frac{r}{r-1}} = \left(\frac{300}{350}\right)^{\frac{1.4}{1.4-1}}$$

$$P_Q = 87.4 \text{ kPa}$$

Linked Answer Questions

Statement for Linked Answer Questions Q. 52 and Q. 53:

The temperature and pressure of air in a large reservoir are 400 K and 3 bar respectively. A converging – diverging nozzle of exit area 0.005 m^2 is fitted to the wall of the reservoir as shown in the figure. The static pressure of air at the exit section or isentropic flow through the nozzle is 50 kPa. The characteristic gas constant and the ratio of specific heats of air are 0.287 kJ.kgK and 1.4 respectively.

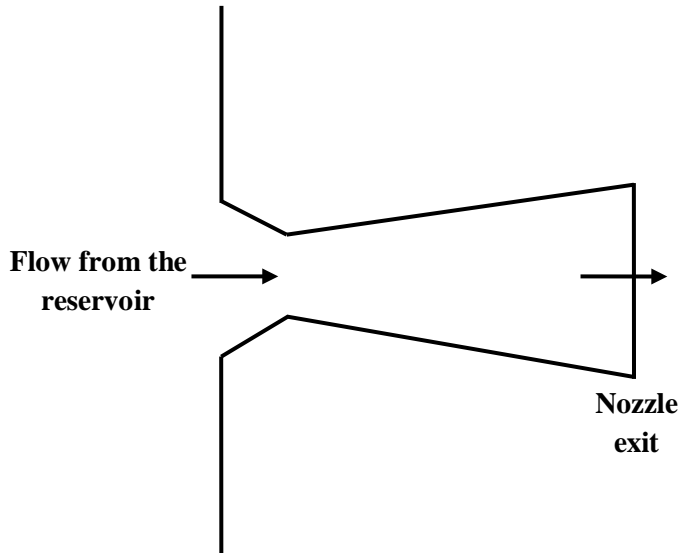

52. The density of air in kg/m^3 at the nozzle exit is

- (A) 0.560 (C) 0.727
(B) 0.600 (D) 0.800

[Ans. C]

$$P_1 = 300 \text{ kPa}, T_1 = 400 \text{ K}$$

$$\text{Pressure at exit, } P_2 = 50 \text{ kPa}$$

$$\text{Temperature at exit, } T_2 = T_1 \left(\frac{P_2}{P_1} \right)^{\frac{\gamma-1}{\gamma}}$$

$$T_2 = 400 \times \left(\frac{50}{300} \right)^{\frac{1.4-1}{1.4}}$$

$$T_2 = 239.7 \text{ K}$$

$$\text{Density at exit, } \rho_2 = \frac{P_2}{R T_2}$$

$$= \frac{50}{0.287 \times 239.7} = 0.727 \text{ kg/m}^3$$

53. The mass flow rate of air through the nozzle in kg/s is

- (A) 1.30 (C) 1.85
(B) 1.77 (D) 2.06

[Ans. D]

$$\text{Velocity at exit, } V_2 = \sqrt{2(h_2 - h_1)}$$

$$V_2 = \sqrt{2C_P (T_2 - T_1)}$$

$$V_2 = \sqrt{2 \times 1005 \times (400 - 239.7)}$$

$$V_2 = 567.6 \text{ m/s}$$

$$\begin{aligned} \text{Mass flow rate, } m &= \rho_2 A_2 V_2 = 0.727 \times 0.005 \times 567.6 \\ &= 2.06 \text{ kg/s} \end{aligned}$$

Statement for Linked Answer Question Q. 54 and Q 55:

A triangular – shaped cantilever beam of uniform – thickness is shown in the figure. The Young's modulus of the material of the beam is E . A concentrated load P is applied at the free end of the beam.

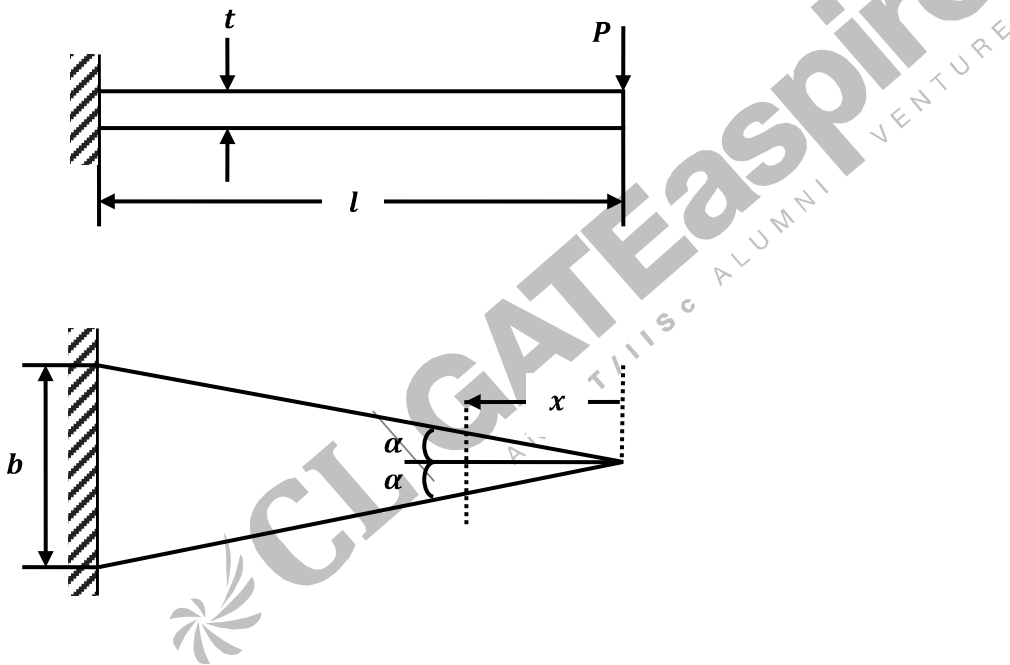

54. The area moment of inertia about the neutral axis of a cross – section at a distance x measure from the free end is

(A) $\frac{bxt^3}{6l}$

(C) $\frac{bxt^3}{24l}$

(B) $\frac{bxt^3}{12l}$

(D) $\frac{xt^3}{12}$

[Ans. B]

At any distance x

$$h = \frac{b}{l} x$$

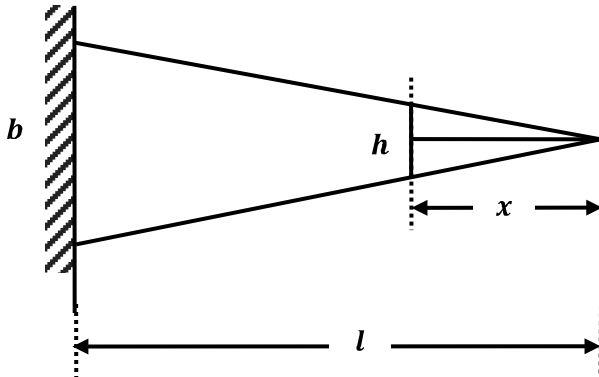

Area moment of inertia,

$$= \frac{b}{l} x \cdot \frac{t^3}{12} = \frac{bxt^3}{12l}$$

55. The maximum deflection of the beam is

(A) $\frac{24 Pl^3}{Ebt^3}$

(B) $\frac{12 Pl^3}{Ebt^3}$

(C) $\frac{8 Pl^3}{Ebt^3}$

(D) $\frac{6 Pl^3}{Ebt^3}$

[Ans. D]

Strain Energy,

$$U = \int_0^L \frac{M^2 dx}{2EI}, [M = Px]$$

$$U = \int_0^L \frac{(P \cdot x)^2 dx}{2 \times E \frac{bxt^3}{12L}} = \frac{6LP^2}{Ebt^3} \int_0^L x dx$$

$$U = \frac{6LP^2}{Ebt^3} \cdot \frac{L^2}{2} = \frac{3L^3 P^2}{Ebt^3}$$

$$\delta_{tip} = \frac{\partial U}{\partial P} = \frac{3 PL^3}{Ebt^3}$$

General Aptitude (GA) Questions

Q. 56 – Q. 60 carry one mark each.

56. Choose the most appropriate word (s) from the options given below to complete the following sentence.

I Contemplated _____ Singapore for my vacation but decided against it.

- (A) to visit
(B) having to visit
- (C) visiting
(D) for a visit

[Ans. C]

Contemplate is a transitive verb and hence is followed by a gerund. Hence the correct usage of contemplate is verb+ ing form.

57. Which of the following options is the closest in the meaning to the word below:

Inexplicable

- (A) incomprehensible
(B) indelible
- (C) inextricable
(D) infallible

[Ans. A]

Inexplicable means not explicable; that cannot be explained, understood, or accounted for. So the best synonym here is incomprehensible.

58. Choose the most appropriate word from the options given below to complete the following sentence.

If you are trying to make a strong impression on your audience, you cannot do so by being understated, tentative or _____.

- (A) hyperbolic
(B) restrained
- (C) argumentative
(D) indifferent

[Ans. B]

The tone of the sentence clearly indicates a word that is similar to understated is needed for the blank. Alternatively, the word should be antonym of strong (fail to make strong impression). Therefore, the best choice is restrained which means controlled/reserved/timid.

59. If $\log(P) = (1/2) \log(Q) = (1/3) \log(R)$, then which of the following options is **TRUE**?

- (A) $P^2 = Q^3 R^2$
(B) $Q^2 = PR$
- (C) $Q^2 = R^3 P$
(D) $R = P^2 Q^2$

[Ans. B]

$$\log P = \frac{1}{2} \log Q = \frac{1}{3} \log(R) = k$$

$$\therefore P = b^k, Q = b^{2k}, R = b^{3k}$$

$$\text{Now, } Q^2 = b^{4k} = b^{3k} b^k = PR$$

60. Choose the word from the options given below that is most nearly opposite in meaning to the given word:

Amalgamate

(A) merge

(C) collect

(B) split

(D) separate

[Ans. B]

Amalgamate means combine or unite to form one organization or structure. So the best option here is split. Separate on the other hand, although a close synonym, it is too general to be the best antonym in the given question while Merge is the synonym; Collect is not related.

Q. 61 to Q. 65 carry two marks each

61. The variable cost (V) of manufacturing a product varies according to the equation $V = 4q$, where q is the quantity produced. The fixed cost (F) of production of same product reduces with q according to the equation $F = 100/q$. How many units should be produced to minimize the total cost (V + F)?

(A) 5

(C) 7

(B) 4

(D) 6

[Ans. A]

Checking with all options in formula: $(4q + 100/q)$ i.e. (V + F). Option A gives the minimum cost.

62. **Few school curricula include a unit on how to deal with bereavement and grief, and yet all students at some point in their lives suffer from losses through death and parting.**

Based on the above passage which topic would not be included in a unit on bereavement?

(A) how to write a letter of condolence

(B) what emotional stages are passed through in the healing process

(C) what the leading causes of death are

(D) how to give support to a grieving friend

[Ans. C]

The given passage clearly deals with how to deal with bereavement and grief and so after the tragedy occurs and not about precautions. Therefore, irrespective of the causes of death, a school student rarely gets into details of causes – which is beyond the scope of the context. Rest all are important in dealing with grief.

63. A transporter receives the same number of orders each day. Currently, he has some pending orders (backlog) to be shipped. If he uses 7 trucks, then at the end of the 4th day he can clear all the orders. Alternatively, if he uses only 3 trucks, then all the orders are cleared at the end of the 10th day. What is the minimum number of trucks required so that there will be no pending order at the end of the 5th day?
- (A) 4 (C) 6
(B) 5 (D) 7

[Ans. C]

Let each truck carry 100 units.

$$2800 = 4n + e \quad n = \text{normal}$$

$$3000 = 10n + e \quad e = \text{excess/pending}$$

$$\therefore n = \frac{100}{3}, e = \frac{8000}{3}$$

$$5 \text{ days} \Rightarrow 500x = \frac{5,100}{3} + \frac{8000}{3}$$

$$\Rightarrow 500x = \frac{8500}{3} \Rightarrow x > 5$$

Minimum possible = 6

64. P, Q, R and S are four types of dangerous microbes recently found in a human habitat. The area of each circle with its diameter printed in brackets represents the growth of a single microbe surviving human immunity system with 24 hours of entering the body. The danger to human beings varies proportionately with the toxicity, potency and growth attributed to a microbe shown in the figure below:



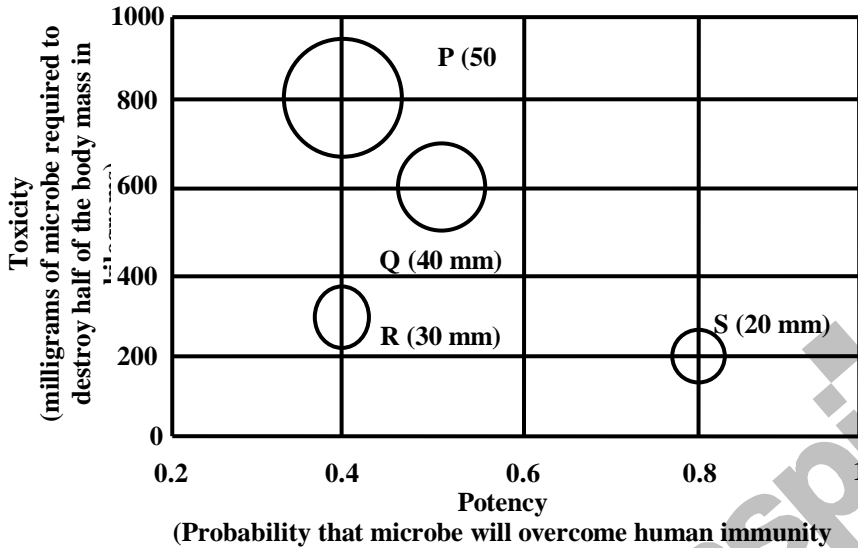

A pharmaceutical company is contemplating the development of a vaccine against the most dangerous microbe. Which microbe should the company target in its first attempt?

- (A) P
- (B) Q
- (C) R
- (D) S

[Ans. D]

By observation of the table, we can say S

	P	Q	R	S
Requirement	800	600	300	200
Potency	0.4	0.5	0.4	0.8

65. A container originally contains 10 litres of pure spirit. From this container 1 litre of spirit is replaced with 1 litre of water. Subsequently, 1 litre of the mixture is again replaced with 1 litre of water and this process is repeated one more time. How much spirit is now left in the container?

- (A) 7.58 litres
- (B) 7.84 litres
- (C) 7 litres
- (D) 7.29 litres

[Ans. D]

$$10 \left(\frac{10-1}{10} \right)^3 = 10 \left(\frac{9}{10} \right)^3 = \frac{729}{1000}$$

$$\therefore \frac{729}{1000} \times 1 = 7.29 \text{ litres}$$